

# Ergo-Boost Foot Rocker



# Ergo-Boost

## Foot Rocker

### Stay active while you work

When you are sitting in front of a screen all day, it can be challenging to remain active. The Ergo-Boost Foot Rocker allows for low impact movement by rocking your feet, providing additional lower leg mobility while sitting. When not in use as a rocker, it can be utilised as an elevated ergonomic footrest, for added comfort.



### Why choose Ergo-Boost Foot Rocker?

#### Choice of exercise settings

The 2-in-1 design means that you can choose between a slow rocking motion (high setting) and a quick rocking motion (low setting) for different exercise rhythms.

#### Added comfort

Choose between two different height positions for added comfort when using as a footrest.

#### Anti-slip design

For added stability.

#### Reduces fatigue

When not in use as a rocker, the Ergo-Boost Foot Rocker can be utilised as an elevated ergonomic footrest.

#### Compact

The foot rocker is unobtrusive and compact enough to store away under the desk when not in use.

#### Peace of mind

5 years warranty, for peace of mind.



# Ergo-Boost

## Foot Rocker

- 1 Setting for slow rocking motion (high setting)
- 2 Setting for quick rocking motion (low setting)
- 3 Anti-slip design for stability
- 4 Massage bumps rejuvenate tired feet
- 5 Compact size for easy storage
- 6 Choice of height position



# Ergo-Boost

## Foot Rocker

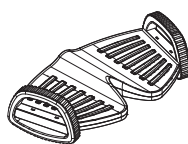
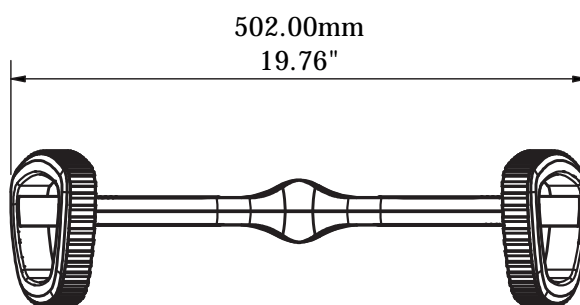
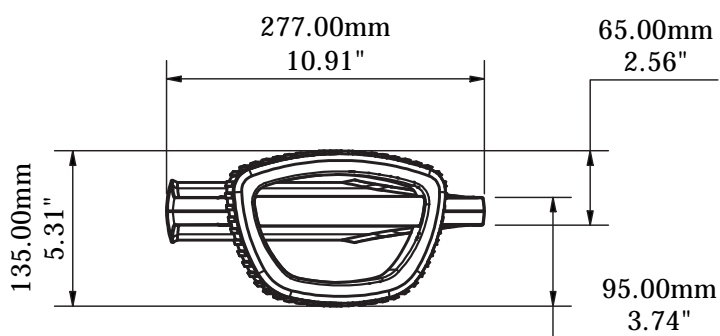
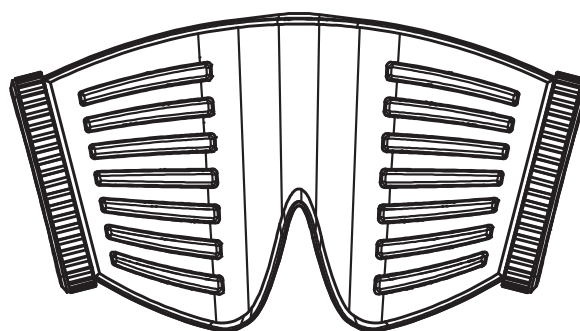

Ergo-Boost Foot Rocker	Weight capacity	Tilt range	Material	Colour
FR001	10kg	+45° / -45° (high setting) +10°/-10° (low setting)	Plastic	Black



Create workspaces that work.

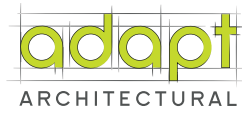

Solutions to build modern commercial spaces more quickly and efficiently.



Unlock workspace potential.



Ergonomic consultancy and software to improve employee health and productivity.

[www.adapt-global.com](http://www.adapt-global.com)

