

Description	Offers greater height adjustment than the standard arm, making it suitable for use on static and height adjustable desks.
Adjustment	5mm Allen Key
Monitor Weight	Lightweight - (0.9kg - 4.53kg) Standard - (2.26kg - 7.25kg) Heavy Duty - (6.80kg - 13.6kg).
Mounting	75mm and 100mm VESA Mounting Centres, 'Quick Change' or 'Direct Mount'
Construction	Aluminium die casting, steel and nylon
Finish & Colour	Powder coated, Platinum, Black, White or Soft White.
Fixings	Included for mounting and monitor
Packaging	Product dependent

These drawings are based on the Quick Change mounting option. For other mounting options please contact your local representative.

Bolt Through - BT

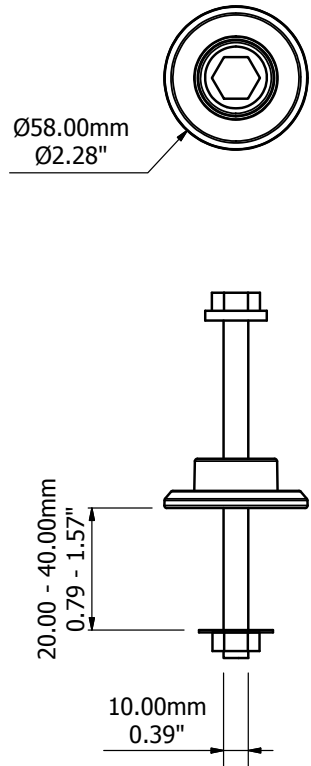

Grommet Mount - GT

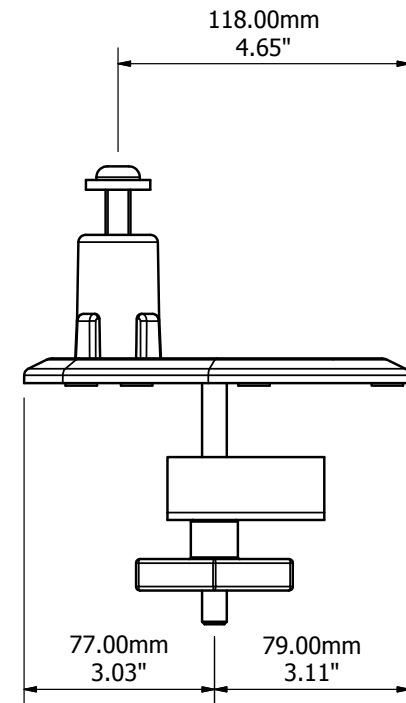
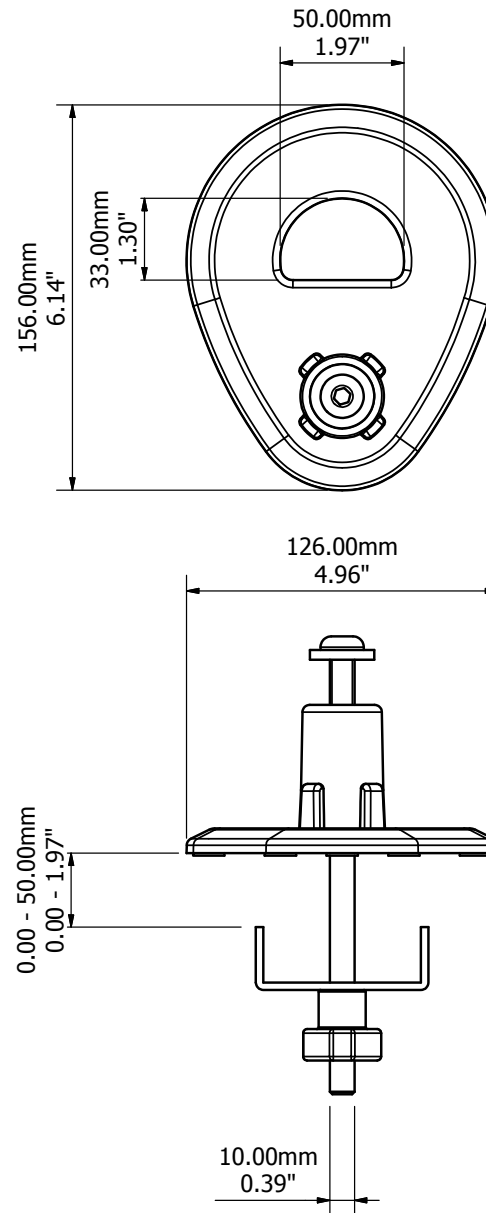

C-Clamp - CC

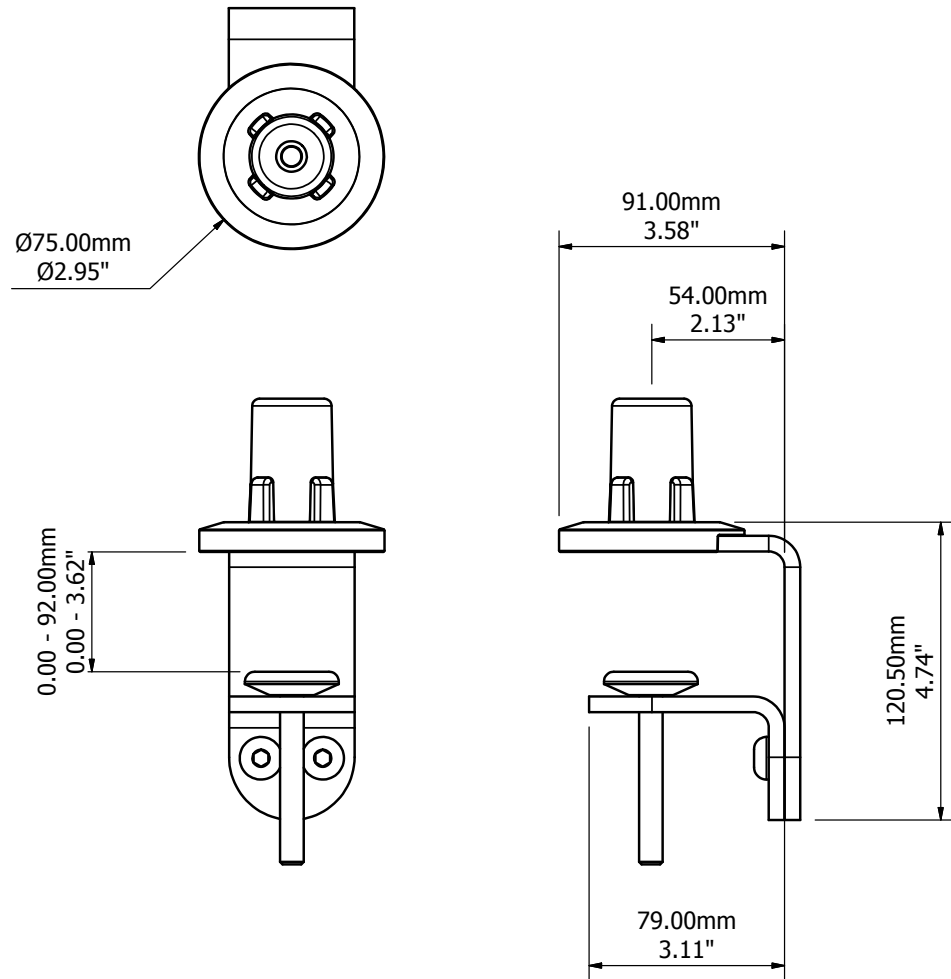

Large C-Clamp - CL

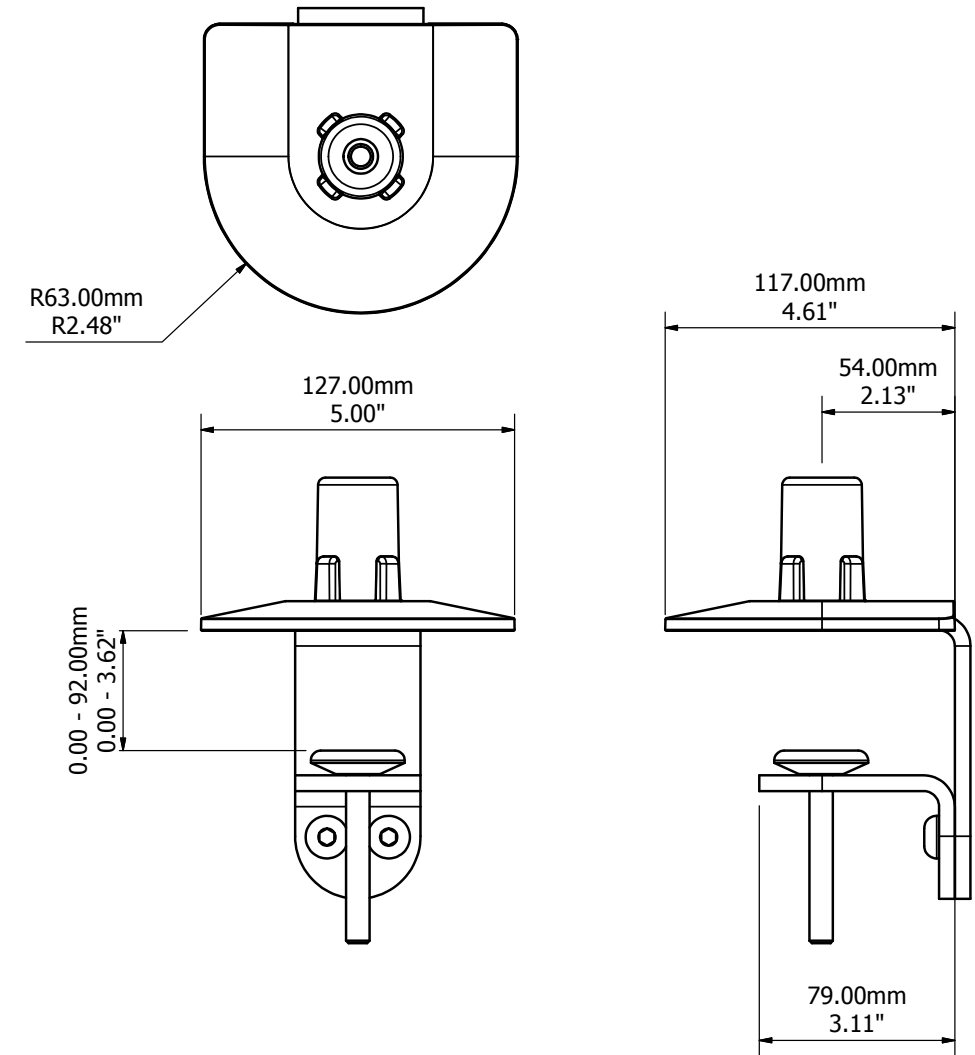

Above Desk Clamp - AC

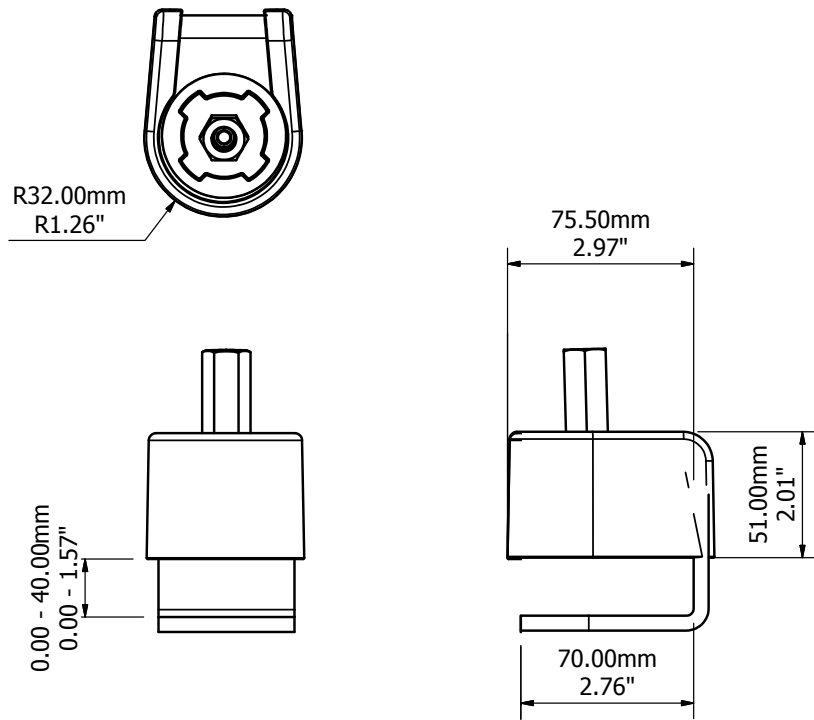

SpaceBeam I Mount - BM

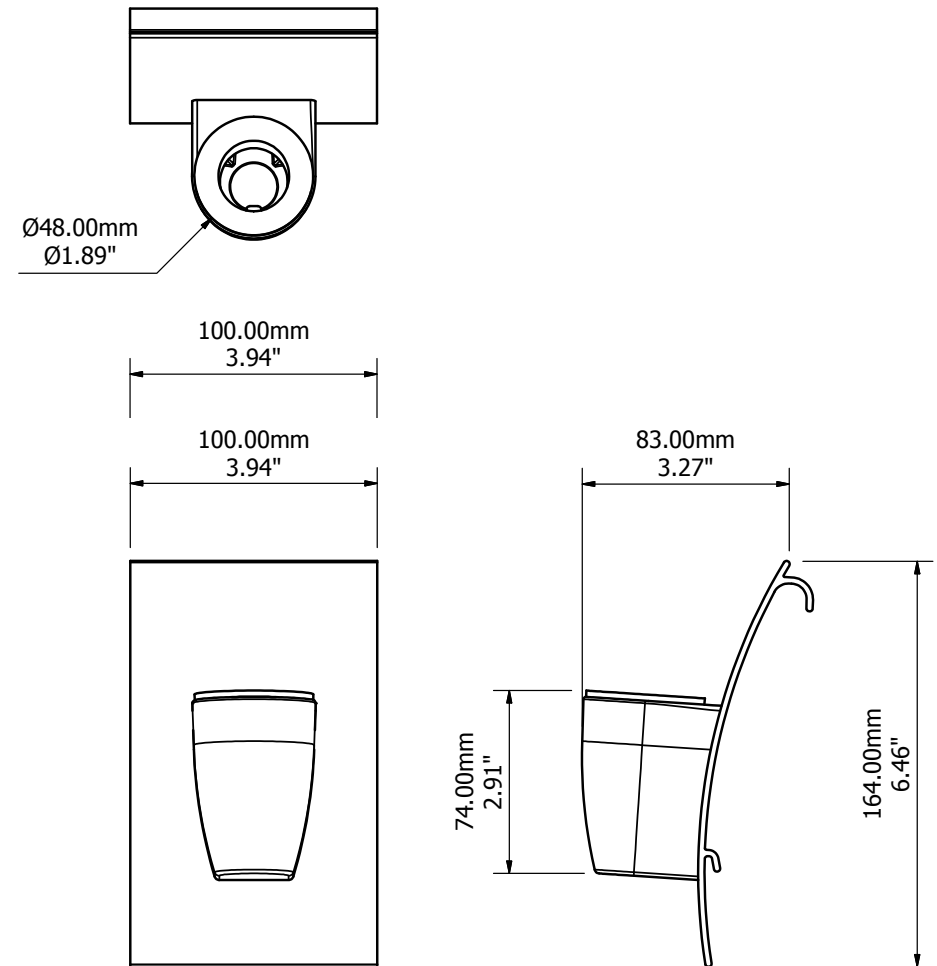

SpaceBeam II Mount - VM-ADJL4

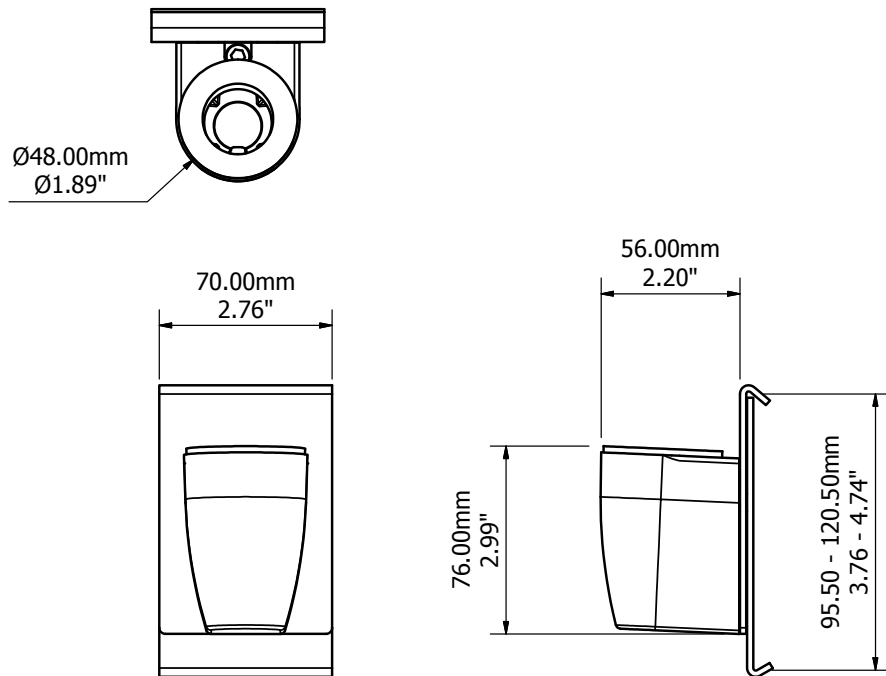

Small C-Clamp - SPCA

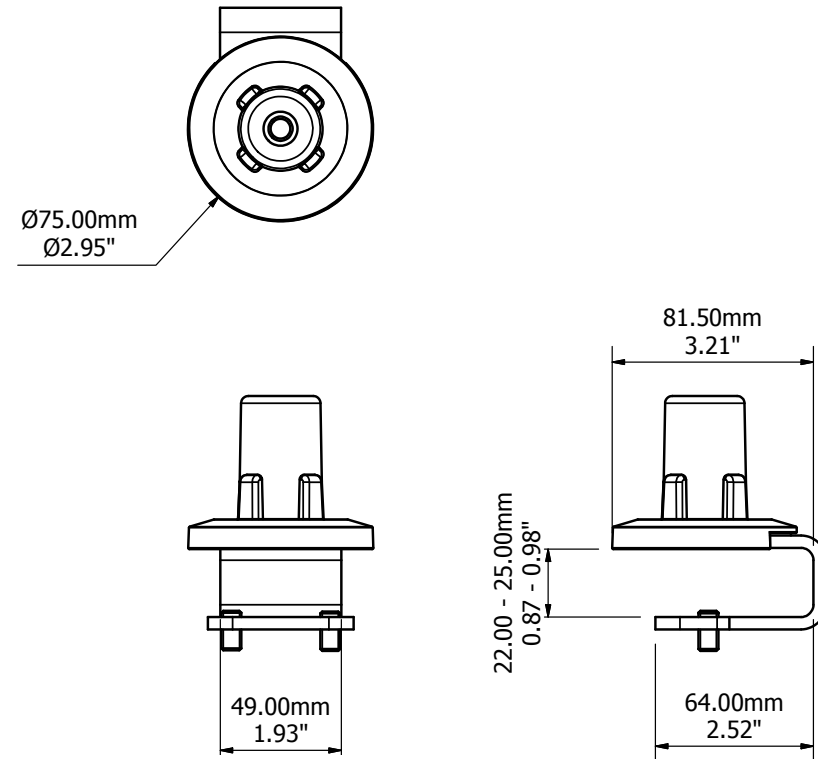

Mini Clamp - MCC

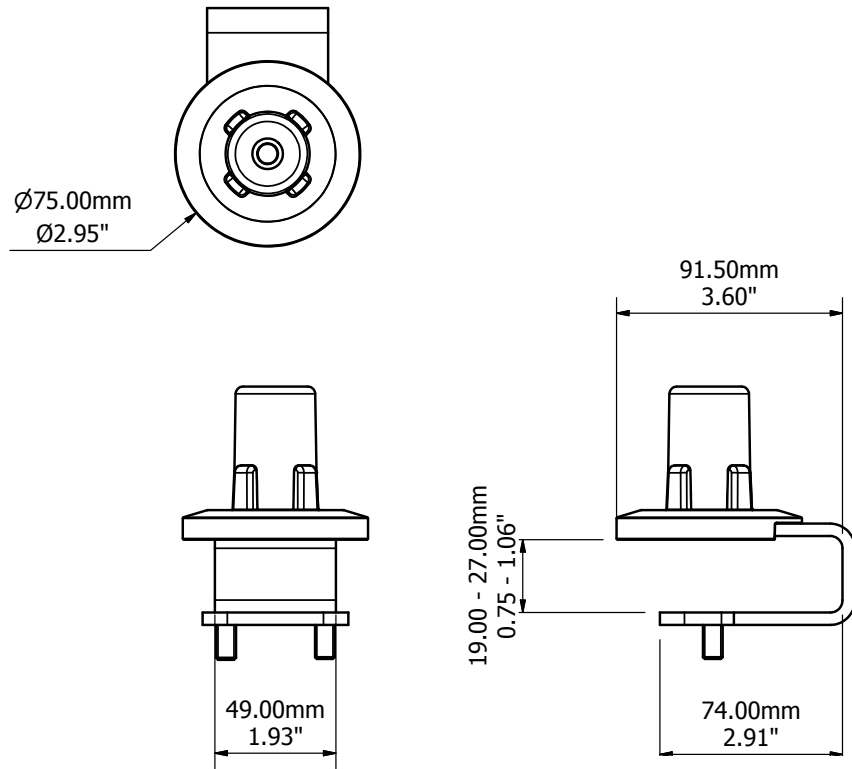

Mini CL Clamp - MCL

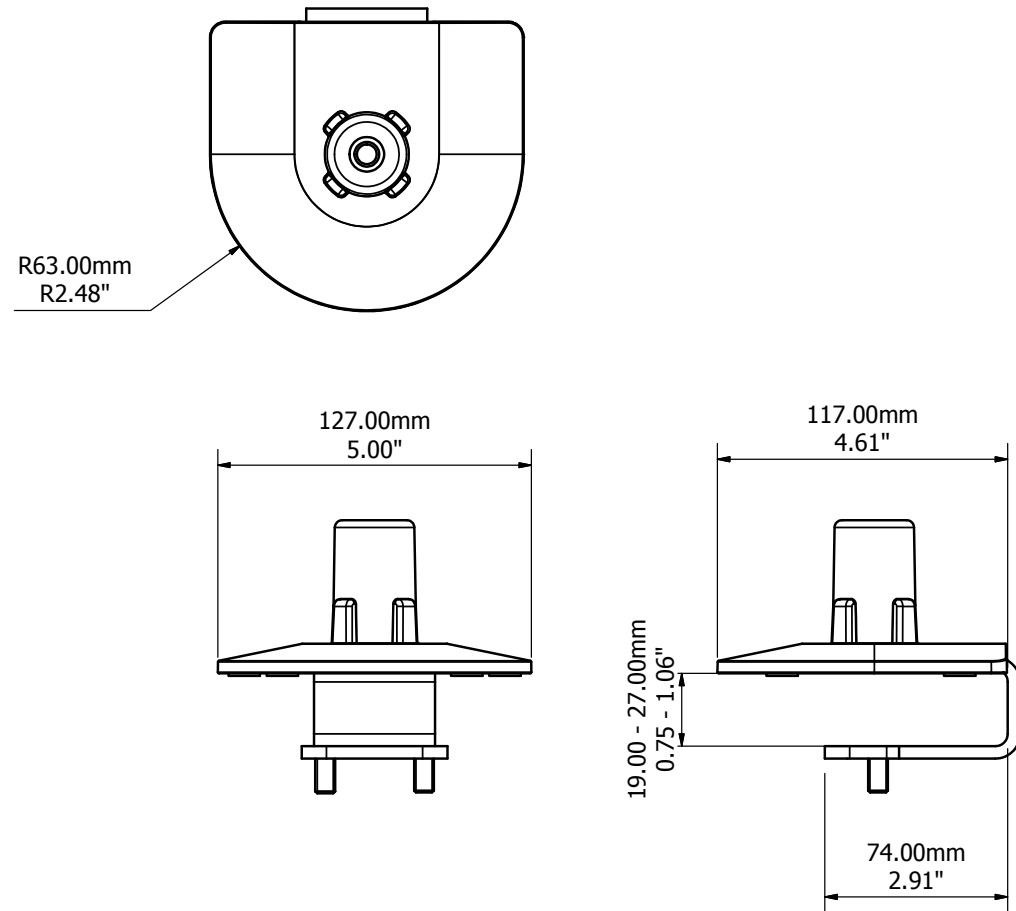

HCC Clamp - HCC

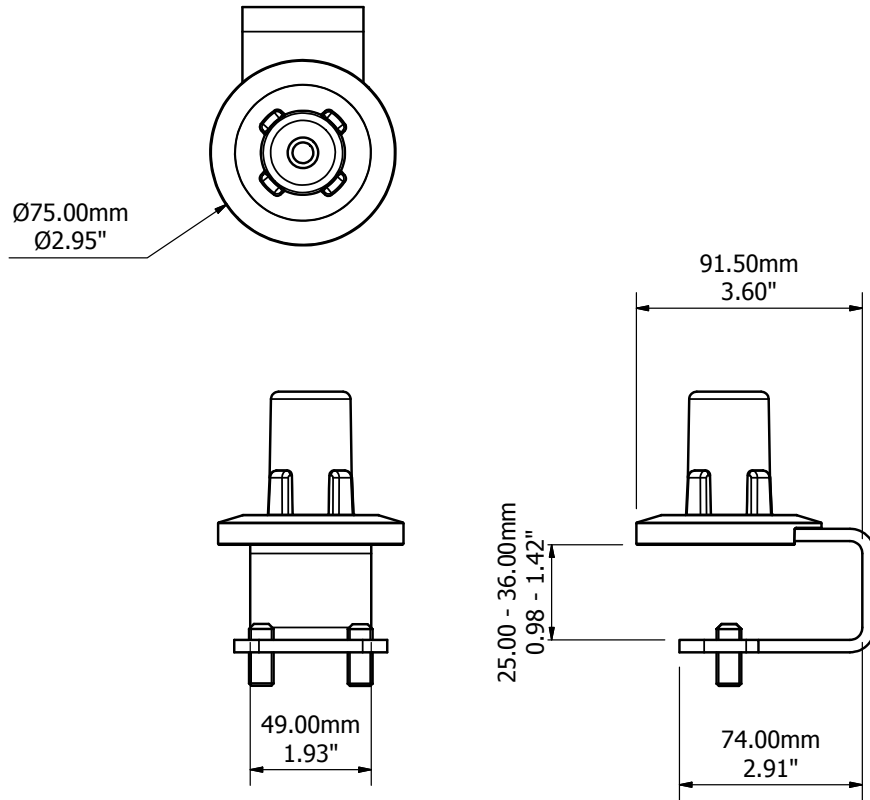

HCL C-Clamp - HCL

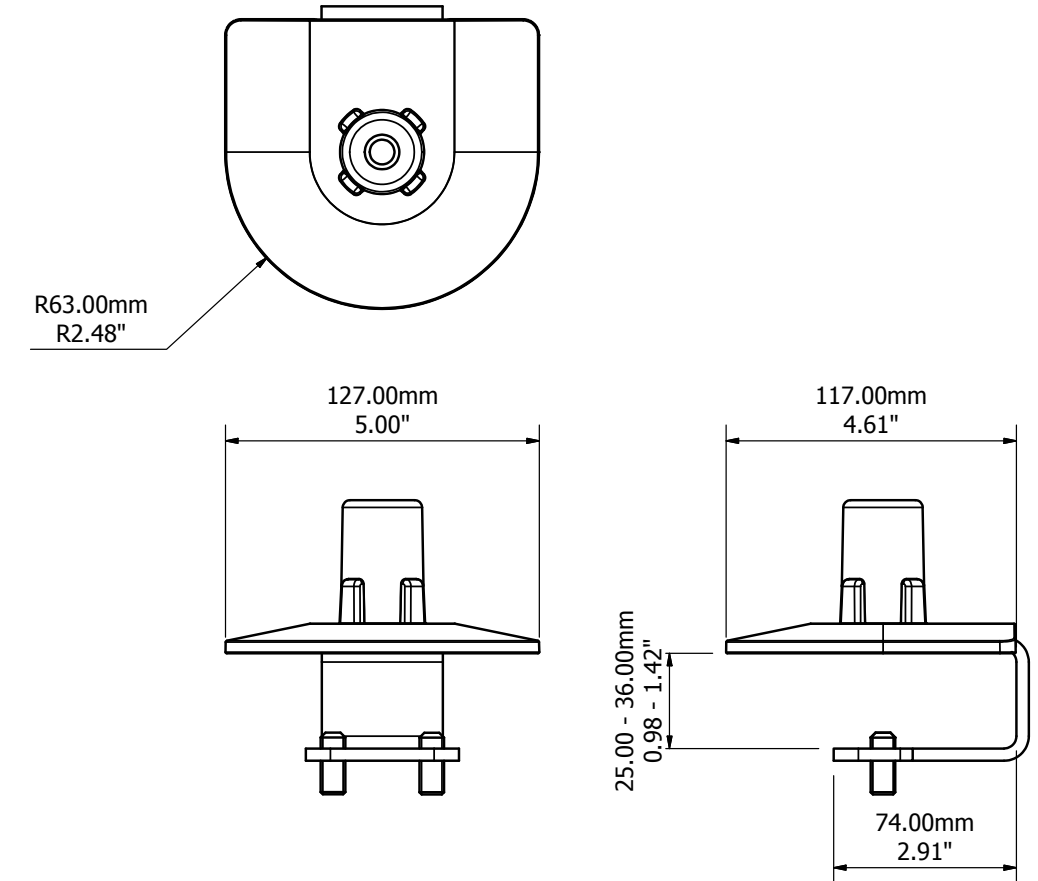

Wall Mount - VM-WM

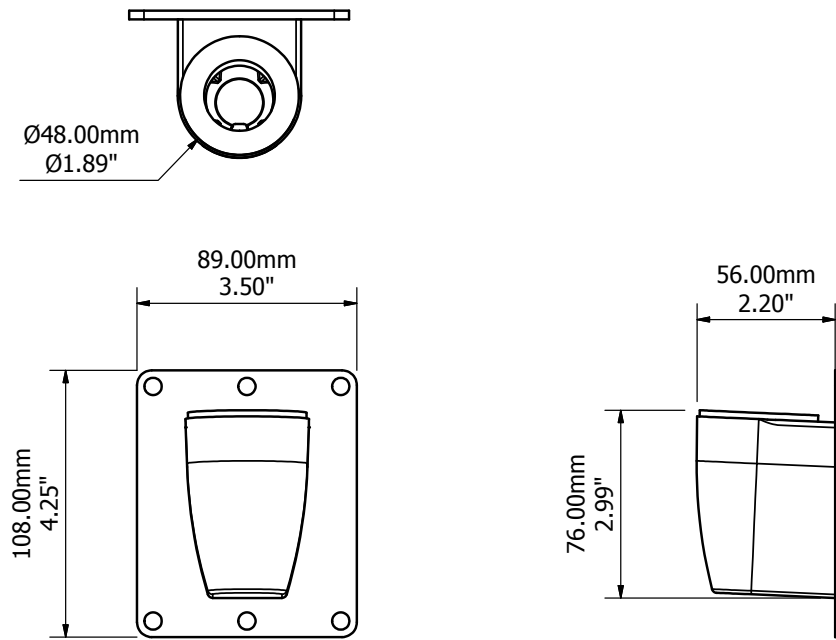

Asia

China

infocn@adapt-global.com

Hong Kong

infohk@adapt-global.com

Philippines

infohk@adapt-global.com

Europe

France

infofr@adapt-global.com

Germany

infode@adapt-global.com

United Kingdom

infouk@adapt-global.com

North America

Canada

infocdn@adapt-global.com

Mexico

infomx@adapt-global.com

USA

infousa@adapt-global.com